

新随我动掣电而行

专注新能源车辆及充放电设施、风光储能系统等领域

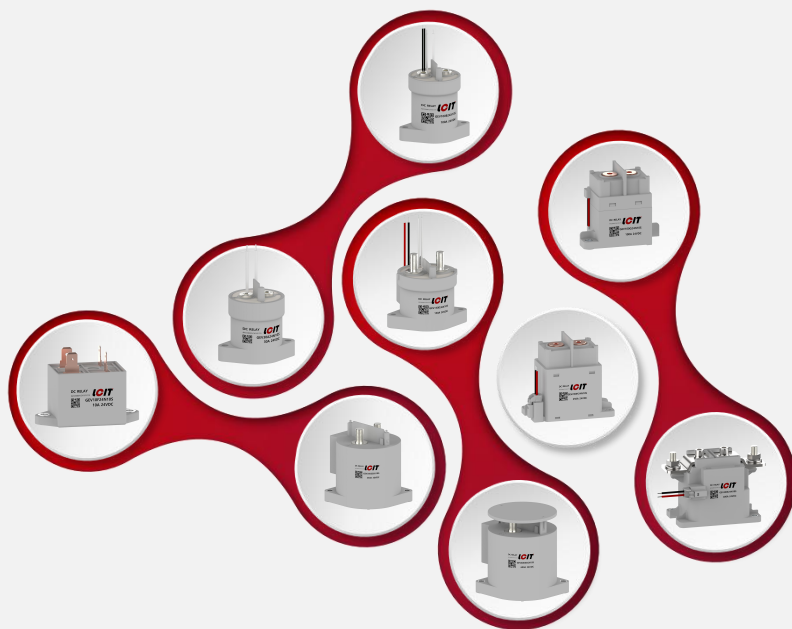

150A GEV150C

应用领域 Application field

高压直流 High voltage direct current	工商业车辆、通讯、低速车辆、家庭储能、5G通讯、充换电站 Industrial and commercial vehicles, communications, low-speed vehicles, home energy storage, 5G communications, charging and changing power stations 电动汽车、环卫车辆、充电桩、光伏、工商业储能、重卡、岸电 Electric vehicles, sanitation vehicles, charging piles, photovoltaic, industrial and commercial energy storage, heavy trucks, shore power	
--	---	---

线圈参数 Coil parameter : 20°C 【±10%】

额定电压 Rated voltage	吸合电压 Pick-up voltage	释放电压 release voltage	最大吸合电压 Maximum pick-up voltage	额定电阻±5% rated resistance	线圈电流mA Coil current	线圈功率 Coil power
12 VDC	≤ 9 VDC	≥ 1.2 VDC	16 VDC	25 Ω	480	5.8 W
24 VDC	≤ 18 VDC	≥ 2.4 VDC	32 VDC	110 Ω	220	5.5 W
36 VDC	≤ 27 VDC	≥ 3.6 VDC	45 VDC	230 Ω	157	5.6 W
48 VDC	≤ 36 VDC	≥ 4.8 VDC	64 VDC	410 Ω	117	5.6 W

性能参数 Performance parameter : 20°C

主触点形式 Main contact form	SPST-NO
辅助触点 Auxiliary contact	SPST-NO
负载电压 Load voltage	12 ~ 1000Vdc
负载电流 Load current	1 ~ 150A
短时耐受电流及时间 Short-time withstand current and time	200A 600Sec. 400A 30Sec.
最大分断电流 Maximum breaking current	1000A (450VDC) 1次
接触电阻 (初始) Contact resistance (Inception)	≤ 1mΩ (at 150A)
吸合时间 Pickup time	Max. 25ms
弹跳时间 Bounce time	Max. 5ms
释放时间 Release time	Max. 10ms
机械耐久性 Mechanical Endurance	3×10 ⁵ 次
电耐久性 (阻性负载) Electrical durability (Resistive load)	200Vdc 1×10 ⁴ 次/450Vdc 1×10 ⁴ 次 100A 750Vdc 1×10 ³ 次
辅助触点最大负载 Maximum load of auxiliary contact	2A, 30VDC / 3A, 125VAC
辅助触点最小负载 Minimum load of auxiliary contact	100mA, 8VDC
辅助触点接触电阻 Auxiliary contact contact resistance	0.50Ω @ 30VDC / 0.15Ω @ 125VAC
介质耐压触点与线圈间 Between dielectric withstand voltage contact and coil	3500VAC 1min
介质耐压断开触点间 Between dielectric withstand voltage breaking contacts	3500VAC 1min
初始绝缘电阻 Initial insulation resistance	1000mΩ (1000Vdc)
振动 Vibration	10Hz ~ 500Hz 49m/s ²
冲击稳定性 Impact stability	196m/s ²
冲击强度 Impact strength	490m/s ²
湿度 humidness	5% ~ 85%RH
温度 temperature	-40°C ~ 85°C
海拔高度 altitude	≤ 4000m
重量 weight	约about 300g

订货标记示例 Order mark example

GEV	150	C	24	X	10	S
↓	↓	↓	↓	↓	↓	↓
LCIT企业 EV继电器代码 LCIT enterprise EV relay code	额定电流A Rated current A	壳体编码 Shape coding	线圈电压 Coil voltage 12:12Vdc,24:24Vdc 36:36Vdc,48:48Vdc	辅助触点 Auxiliary contact N = None X = SPST-NO C = SPST-NC	负载电压 Load voltage 10=12-1000Vdc	主触点极性 Main contact polarity S=有 have

外形尺寸、接线图、安装孔尺寸

Overall dimensions, wiring diagram, mounting hole dimensions

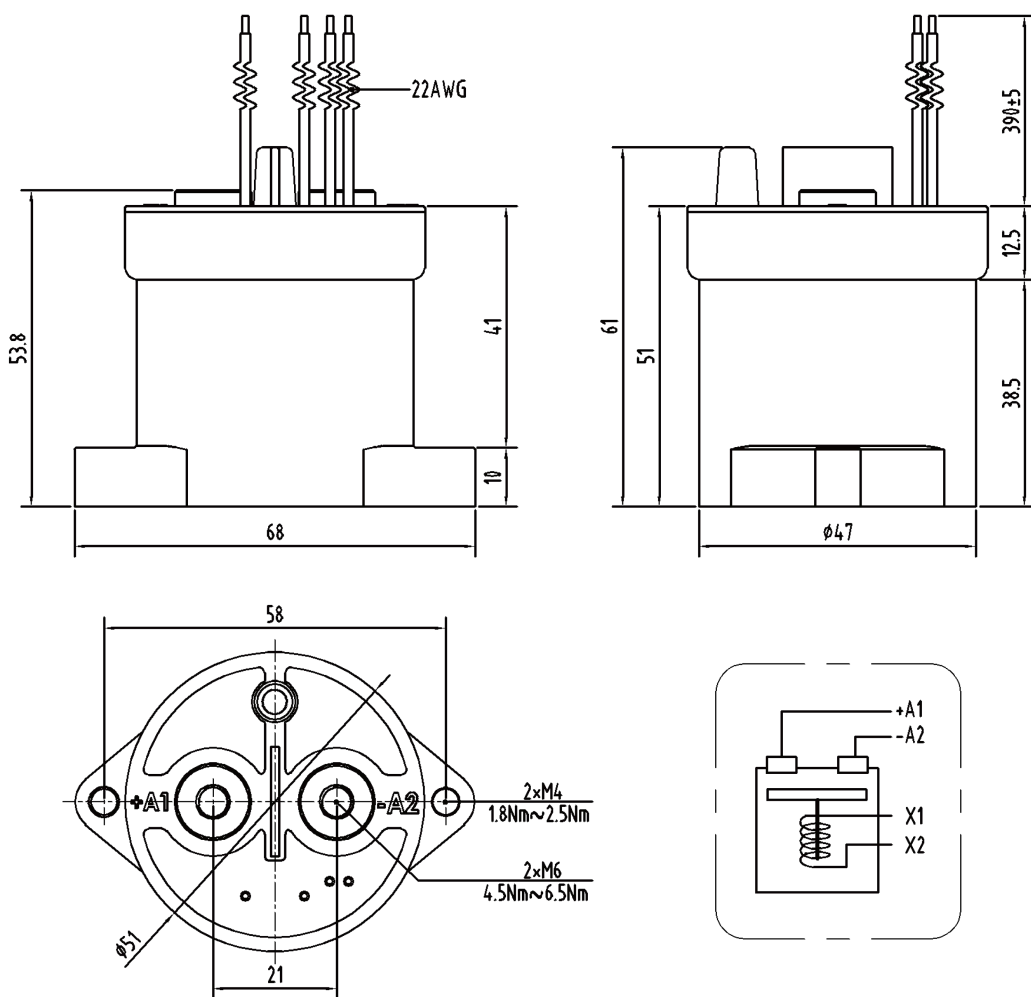

- 产品部分外形尺寸未注尺寸公差，
当外形尺寸 $\leq 10\text{mm}$ ，公差 $\pm 0.3\text{mm}$ ；
当外形尺寸 在 $(10 \sim 50)\text{mm}$ 之间时，公差为 $\pm 0.5\text{mm}$ ；
当外形尺寸 $\geq 50\text{mm}$ ，公差为 $\pm 0.8\text{mm}$ 。
- 公差仅供参考，当与实物不一致时，请以实物尺寸为准。

- No dimensional tolerances have been noted in the overall dimensions of some products.
When the overall size is $\leq 10\text{mm}$, the tolerance is $\pm 0.3\text{mm}$;
When the overall size is between $(10 \sim 50)\text{mm}$, the tolerance is $\pm 0.5\text{mm}$;
When the overall size is $\geq 50\text{mm}$, the tolerance is $\pm 0.8\text{mm}$.
- Tolerance is for reference only, when inconsistent with the real size, please refer to the real size.



Shanghai Lcit Industrial Co.,Ltd.
www.lcitind.com www.lcitind.cn
+86-21-57646228
880 Ziyue Road, Minhang District, Shanghai